

# BELT CONVEYOR INSTALLATION and OPERATION

O. M. 27733

DATE OF ISSUE: 11/13

REVISION: D, 07/18

## **WARNING**

**Do not use this equipment before READING this MANUAL and UNDERSTANDING its contents.**

**These WARNINGS are included for the health and safety of the operator and those in the immediate vicinity. Failure to read and understand these warnings can result in injury or death.**

**Electronic files include a Preface containing the same important information as in the orange cover.**

© 2018 CLEMCO INDUSTRIES CORP.

One Cable Car Dr.

Washington, MO 63090

Phone (636) 239-4300

Fax (800) 726-7559

Email: [info@clemcoindustries.com](mailto:info@clemcoindustries.com)

[www.clemcoindustries.com](http://www.clemcoindustries.com)

**INDUSTRIAL**  
***Blast Facilities***  
by Clemco Industries Corp.

**1.0 INTRODUCTION**

**1.1 Scope of Guide**

1.1.1 These instructions are general guidelines to assist the user in the sequence of assembly of Clemco belt conveyor recovery systems. Separate instructions are provided for the blast room and other related accessories. All engineered projects manuals have a Table of Content located at the beginning of the manual, which lists all component drawings and accessory manuals. The general arrangement drawings and assembly drawings provided with the project manual contains specific information pertaining to the conveyor system purchased. Use this guide along with to the assembly drawings and accessory manuals, for placement and assembly of the conveyor. Reviewing the process and the complete set of assembly drawings before beginning the installation will simplify the construction.

Separate manuals provide instructions on use of equipment used in combination with the belt conveyor.

These include:	Manual Number
Bucket Elevator .....	21822
Elevator Underspeed Monitor .....	21431
Abrasive Cleaner .....	20547
Engineered Products Blast Machine .....	23404

For additional copies, visit [www.clemcoindustries.com](http://www.clemcoindustries.com) or email [info@clemcoindustries.com](mailto:info@clemcoindustries.com).

Read this entire manual before attempting installation or operation of the recovery system.

**1.2 Safety Alerts**

1.2.1 Clemco uses safety alert signal words, based on ANSI Z535.4-2011, to alert the user of a potentially hazardous situation that may be encountered while operating this equipment. ANSI's definitions of the signal words are as follows:



**This is the safety alert symbol. It is used to alert you to potential physical injury hazards. Obey all safety messages that follow this symbol to avoid possible injury or death.**

**NOTICE**

**Notice indicates information that is considered important, but not hazard-related, if not avoided, could result in property damage.**

**⚠ CAUTION**

**Caution indicates a hazardous situation that, if not avoided, could result in minor or moderate injury.**

**⚠ WARNING**

**Warning indicates a hazardous situation that, if not avoided, could result in death or serious injury.**

**⚠ DANGER**

**Danger indicates a hazardous situation that, if not avoided, will result in death or serious injury.**

**1.3 General Description**

1.3.1 Clemco belt conveyor systems generally consist of the belt conveyor assembly, bucket elevator, abrasive cleaner, and blast machine. Refer to the general arrangement drawings and assembly drawings for the conveyor layout and accessory equipment purchased.

1.3.2 The conveyor and hoppers are recessed into a foundation pit, which passes under the blast room wall. The tops of the hoppers are located so the floor grating is at floor level. The hoppers are located inside the blast room for easy loading; the operator uses a broom, shovel, loader, or similar means to push media into the hoppers.

1.3.3 The belt conveyor sits below the hoppers and passes underneath the blast room wall. The elevator and other recovery equipment are kept outside the blast room.

**1.4 Foundation Pit and Anchors**

1.4.1 The foundation work and anchors are to be provided by the purchaser and must be poured prior to the installation. The foundation drawing is provided with the conveyor system. Refer to the foundation drawing before excavating and pouring the foundation pit.

---

## 2.0 EQUIPMENT CHECK AND STORAGE

---

### **NOTICE**

---

All materials must be stored in an area protected from weather and water. Exposure to elements can damage some materials.

---

2.1 Uncrate equipment and identify parts, comparing the checklist with numbers on the drawings, cartons, and parts.

---

### **NOTICE**

---

A pre-coat of rubber cement is applied to both ends of the conveyor belt. Protective covers keep the ends clean; to avoid contaminating ends, which can result in splice failure, do not remove the covers until the belt is installed and ready to splice. Keep the belt, splice cable, clip washers, rubber cement with hardener, and brushes together until ready to install.

---

2.2 Sort parts into groups according to equipment segment, i.e., blast room panels, recovery components, dust collector, blast machine, operator safety equipment, etc. To help keep the assembly area organized, and to avoid loss, leave small parts in marked boxes until they are required.

---

## 3.0 INSPECT and PREPARE ASSEMBLY SITE

---

Refer to the general arrangement drawings for the layout of equipment.

---

### **NOTICE**

---

Moisture or water in recovery equipment causes severe operating problems. Recovery components are not weatherproof; they are designed to be used in a weatherproof enclosure that protects the equipment from condensation and ingress of any moisture or water.

---

3.1 Compare the installation site with the general arrangement drawings. Make sure there is enough unobstructed floor space and height clearance for all components.

3.2 Provide space for access doors, blast machine inspection door, and media recovery segments. Make sure there is ample height and adequate space above the highest component for service.

3.3 Make sure the pit is sized, squared, and level per the foundation drawings. Make sure that drainage is away from the room's perimeter. **NOTE: It is important that the foundation be poured to the specifications on the foundation drawing(s). Work with the contractor and point out all notes on the drawings before the foundation is poured.**

---

## 4.0 INSTALLATION

---

### **WARNING**

---

Failure to observe these warnings can result in serious injury or death.

- Weight and bulk of the components require that erection be performed by experienced personnel who are familiar with safely handling steel material of this sort, using only approved tools and hoists that are required for safe placement of this product.
  - Move equipment using lifting eyes provided on each segment. Never hoist the equipment by legs, handle, piping, or with a sling through anything other than lifting eyes.
  - Keep equipment level and upright when moving and lifting. Use guy-lines to steady the equipment during moving and placement, and to prevent equipment from tipping.
  - Always use appropriately-rated rigging (the lifting device, chains or slings, and attachment hardware), rated higher than the weight of the equipment.
  - Stay clear of equipment being raised or moved; do not work under any elevated equipment.
- 

These instructions pertain to the belt conveyor only. Installation and adjustment of the bucket elevator, abrasive cleaner and blast machine must be made concurrently. Refer to the manuals listed in Paragraph 1.1.1 for detailed installation instructions for each component. All engineered projects manuals have Table of Content where all project components are listed.

## 4.1 PLACEMENT

4.1.1 To prepare, refer to the assembly drawing and examine the job site to determine the best way to assemble the equipment. If the location provides ample room, place large components after the room is assembled. Keep accessory segments away from the blast room site. If space limitations prevent free

movement of large components after the room is erected, move the components to their approximate location before erecting the room.

**4.2 Assemble Conveyor Sections**

**4.2.1** Unless the conveyor is exceptionally long, conveyors frames are assembled at the factory. Long conveyors are assembled but sections are subsequently disconnected for shipping purposes. These sections need to be bolted together on site.

**4.2.2** Frame sections need to be positioned, hung, and bolted together in the pit. This assembly is done with hanger gauges provided, which locate the frames at the correct depth. Refer to the installation notes and details on the Belt Conveyor Assembly Drawing to install the elevator boot, and hang and install the frame sections. The hoppers will be installed later.

**4.3 Install Belt, Refer to Figure 1**

**NOTE: Make sure the belt is installed to travel in the direction as shown in Figure 1, with the overlap on the trailing end of the belt. Once the splice made and the overlap is cemented, it cannot be redone.**

**A pre-coat of rubber cement is applied to both ends of the belt. Protective covers keep the ends clean; do not remove the covers until the belt is installed and ready to splice per Section 4.3.5.**

**4.3.1** Make sure the orientation of the belt splice and overlap flap is as shown in Figure 1. When the splice is on the upper side, the flap is on the outer surface on the drive side end of the belt.

**4.3.2** Adjust the take-up rods on the idler pulley fully toward the drive, providing maximum slack in the belt.

**4.3.3** Using this method of installation, the belt is installed using the un-flapped end as the lead. Route the belt so it rides **above** the upper support rollers, around the drum motor (drive pulley), and **above** the lower belt support roller assemblies.

**4.3.4** Bring the belt over the idler pulley. **The belt should appear as it does in Figure 1; if it is not as shown, re-route the belt.**

**4.3.5 Splice Belt, Refer to Figure 2**

**4.3.5.1** Place a board or similar object over the top of the frame as shown in Figure 2. The board will be a temporary work surface to complete the splice.

**4.3.5.2** The splice connection is a two or three person operation, one or two to pull the hinge ends together and another to insert the splice cable.

**4.3.5.3** Remove the protective cover from both ends of the belt; take all measures necessary to keep the ends clean. Pull the ends together and mesh the lacing on the hinge strips. When the hinge strips are correctly meshed, the sides of the belt will be aligned straight, not offset.

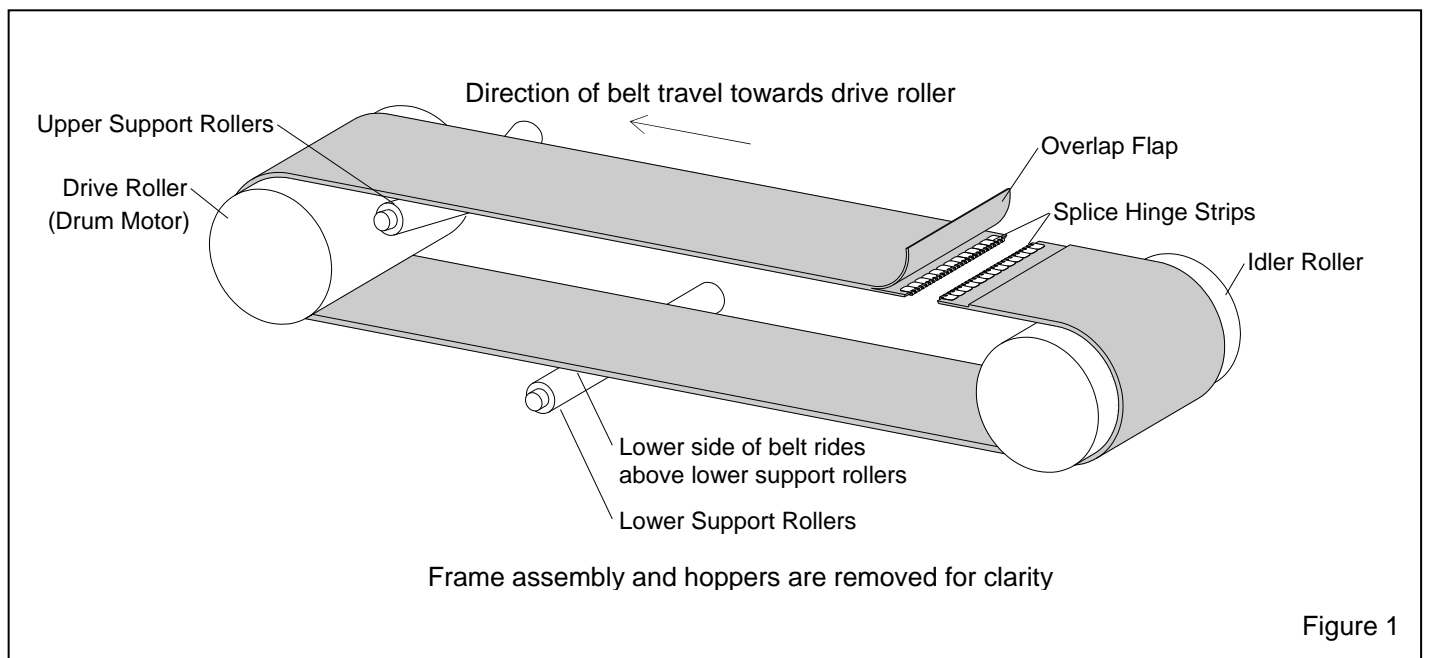

Figure 1

4.3.5.4 Insert the splice cable through the channel created by meshing the hinges strips. It helps to twist the cable as it is inserted through the channel.

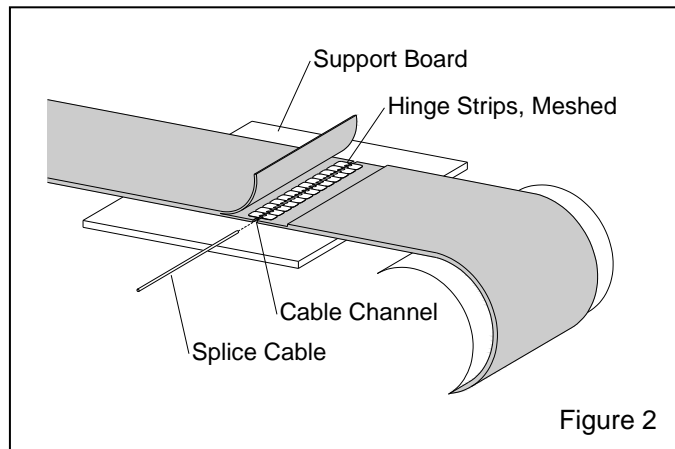

Figure 2

4.3.6 Secure Splice Cable with Clips, Refer to Figure 3.

4.3.6.1 Refer to Figure 3 and align the cable ends with the sides of the belt. Slide one cable clip washer over one end of the splice cable. Note: The clip is bent; install it with the outer edge of the bend facing out, away from the belt. Crimp the clip with a long nose plier in the direction of the bend. Crimp only enough to grip the cable to prevent it from sliding.

4.3.6.2 Use the same process to install another clip on the other end of the splice cable.

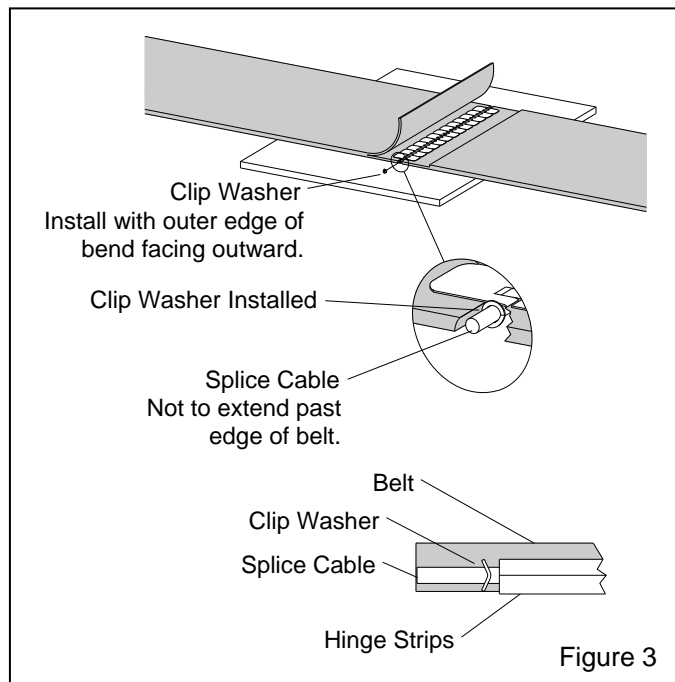

Figure 3

4.3.7 Cement Overlap Flap

## NOTICE

**Make sure the belt is installed as follows. Once the overlap is bonded, it cannot be redone. The belt must be installed as shown in Figure 1 and as follows.**

1. The belt must be installed to travel in the direction shown, toward the drive pulley.
2. The overlap flap is on the trailing end of the belt.
3. The upper side of the belt rides on the upper support rollers.
4. The lower side of the belt rides above all lower support rollers.
5. When the splice is on the upper side of the belt, the overlap flap faces up.

4.3.7.1 Follow mixing instructions on the cement label and mix enough cement and hardener to apply a coat to the shaded areas in Figure 4.

4.3.7.2 Apply a wet layer of cement to the shaded areas as shown, including the hinge strips. Make sure cement is applied to the edges as noted.

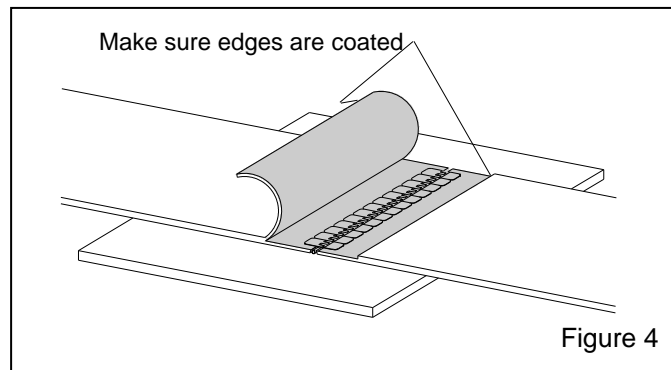

Figure 4

4.3.7.3 After the cement is mixed, it takes 10 to 20 minutes to dry to a tacky texture. Hold or clip the flap to prevent it from touching the mating surface until the cement is slightly tacky.

4.3.7.4 While the cement is still slightly tacky to the touch, press the edges together and press the overlap flap onto the matching recessed surface of the belt. Press the surface until all air pockets are eliminated. Use a roller to press the flap smooth.

4.3.7.5 Apply a weight evenly across the overlap and let the splice dry for 24 hours. **NOTE: Putting the belt into service before the 24-hour cure time will result in failure to bond the overlap, flap peeling, and premature splice failure.**

**4.3.8** After the belt splice has dried, have a qualified electrician apply temporary power. Observe the following alert and adjust the belt tracking per Section 5.1. Make sure the belt is tracking correctly and the conveyor is functioning correctly. Make sure all rollers turn freely.

## WARNING

**Shorting electrical components can result in serious electrical shocks resulting in death, or equipment damage. All electrical work and any work done inside the panel must be performed by a qualified electrician, and comply with applicable codes.**

**4.3.9** While temporarily wired, adjust the elevator feed hopper proximity sensor per Section 5.3.

### 4.4 Final Assembly

**4.4.1** Place the hoppers in the pit and make connections as shown on the belt conveyor assembly drawing.

**4.4.2** Run the conveyor to make sure everything is working correctly and the conveyor is correctly aligned with the elevator inlet chute.

**4.4.3** Assemble the bucket elevator and install grates and cover plates.

## 5.0 ADJUSTMENTS

### 5.1 Belt Tensioning and Tracking

## DANGER

**Tracking is checked visually at both ends of the conveyor while tensioning the belt. The conveyor must be running to insure proper tracking. Extreme care must be taken to keep hands, tools, clothing, etc., away from the conveyor while it is running. Any limbs, loose clothing, tools, or any other articles, catching on a conveyor or any moving parts will cause severe injury. Enlist the aid of another person(s) to observe and stand by the controls to immediately shut off power if necessary.**

NOTE: Tensioning must be done when no abrasive is transported. Adjust the tension using the take-up screws at the back (idler end) of the conveyor. Do not use the adjustment screws at the drive (motor) end. The drive

end screws are to be tightened or loosened only enough to center the belt on the drum motor.

**5.1.1** At least three people are needed during the initial belt tracking adjustment. One person adjusts the take-up screws and monitors the tracking at the idler roller. Another observes the drive roller and makes minor adjustment to keep the belt centered on the roller; the other jogs the drive motor.

**5.1.2** Jog the motor to see if the belt drifts to one side on either the drive roller or the idler roller. Adjust the belt take-up screws on the idler end and the adjustment bolts on the drive end, as needed to center the belt.

**5.1.3** Continue to jog the motor and adjust tracking, progressively increasing the running time until the motor can remain running without the belt drifting.

**5.1.4** While the motor is running, adjust both take-up screws evenly and alternately until the belt is taut enough so the sides of the belt slopes to match the contour of the top rollers. Doing so should place the top of the belt approximately 3/4-inches from the bottom of the hoppers, as shown in Figure 5. While tightening the take-up screws, make sure the belt stays centered on the idler roller and drive roller. Adjust the drive end adjustment bolts as required. NOTE: If the center of the belt drifts to one side, adjust top rollers as follows.

**5.1.4.1** Belts tend to drift toward the high side, which means the roller on the side the belt travels is higher than the one opposite. Lower the roller on the side that drifts toward the edge by loosening the roller mount and move it slightly forward or backward, as noted in Figure 5, until the belt tracks in the center. Tighten the bolts to maintain the setting. If adjustment is required on multiple rollers, stop the conveyor and repeat the process on any roller where the belt drifts. Restart the conveyor and check the tracking to see if additional adjustments are needed.

**5.1.5** After the final adjustment is made, continue to run the belt and check tracking every couple of minutes, gradually increasing the inspection time to make sure there is no long-term drift.

**5.1.6** After abrasive is loaded per Section 6.5, observe tracking while abrasive is transported on the belt, readjust the tracking if necessary.

## NOTICE

**All system components must be operational before continuing. If the system is not operational, the underspeed monitor can shut down the system after approximately seven seconds.**

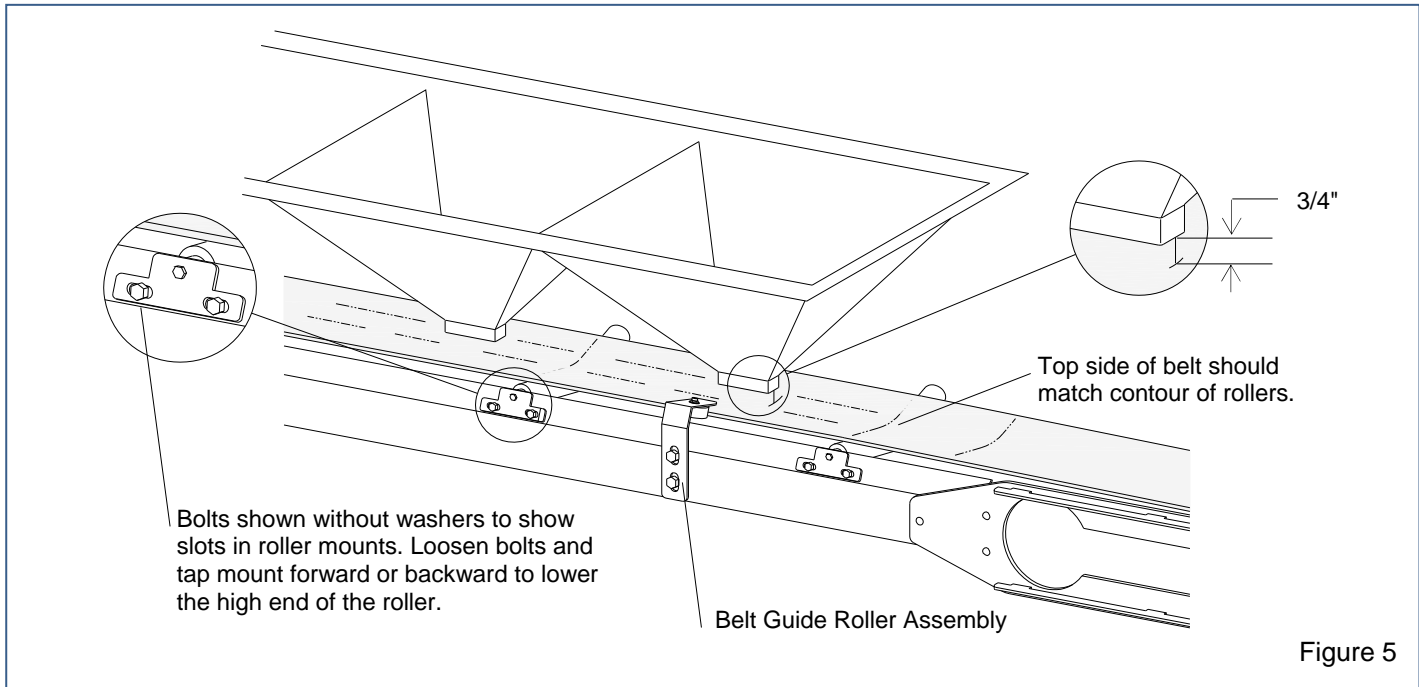

Figure 5

**5.2 BELT SPEED**

**5.2.1** The system is designed to operate at maximum or near maximum transport (motor) speed. The following procedure determines the maximum transport speed, without over-feeding the bucket elevator. Do not run the motor under 30 Hz or over 60 Hz.

**5.2.2** Load hoppers with about six cubic feet of media and set the speed control to around 45 to 50 Hz.

**5.2.3** While monitoring the elevator inlet chute start the recovery system. Observe the abrasive level in the inlet chute and slowly increase motor speed. If abrasive level begins to rise, stop the system and refer to the following excerpt from the bucket elevator manual, and check the adjustment for the inlet chute slide gate.

1. If abrasive flow into the elevator boot is either too great (more abrasive enters the boot than the buckets can carry) or insufficient (buckets pick up too little abrasive and abrasive builds-up in the conveyor or inlet chute while buckets are nearly empty), the flow control slide gate should be adjusted.
2. Lowering the slide gate lowers the abrasive level in the boot and the buckets pick-up less abrasive; raising it, raises the abrasive level and the buckets pick up more abrasive. Always tighten the locking bolt after adjusting the slide gate.
3. When the slide gate is correctly positioned, the buckets pick up a small amount of abrasive on the

upward swing at the bottom pulley. Binding at start-up indicates the slide gate is too high.

**5.2.4** After the inlet chute is adjusted for maximum flow, decrease the motor speed. Increase or decrease the speed as needed, but remain between 30 to 60 Hz. The belt should feed abrasive into the chute no faster than the elevator lifts it.

**5.3 Proximity Sensor**

**5.3.1** The proximity sensor is attached to the sensor mount located in top section of the elevator feed hopper.

**5.3.2** Remove the two fasteners holding the sensor mount to the support plate and remove the sensor mount from the hopper, being careful not to pull cord. The adjustments are made with the sensor in place in the plastic sensor well.

**5.3.3** Refer to Figure 6 for the back view of the sensor and the location of the sensitivity potentiometer. Use the screwdriver provided (usually placed in the control panel), to insert into the hole to make the adjustment. If the original screwdriver is not available, use a small flat lip screwdriver that is no wider than 3/32".

**NOTE:**

- The green light indicates the sensor is receiving electrical power.
- The red light indicates the sensor is open, and the conveyor shuts down.

**5.3.4.** With electrical power supplied, place a small bag of media against the end of the plastic well housing.

- If the red light is lit, use the screwdriver to slowly turn the pot clockwise until the light goes out. The sensor is now set.
- If the red light is not lit, while maintaining media contact, turn the pot counterclockwise until the red light is lit, then slowly turn the pot clockwise until the light goes out. The sensor is now set.

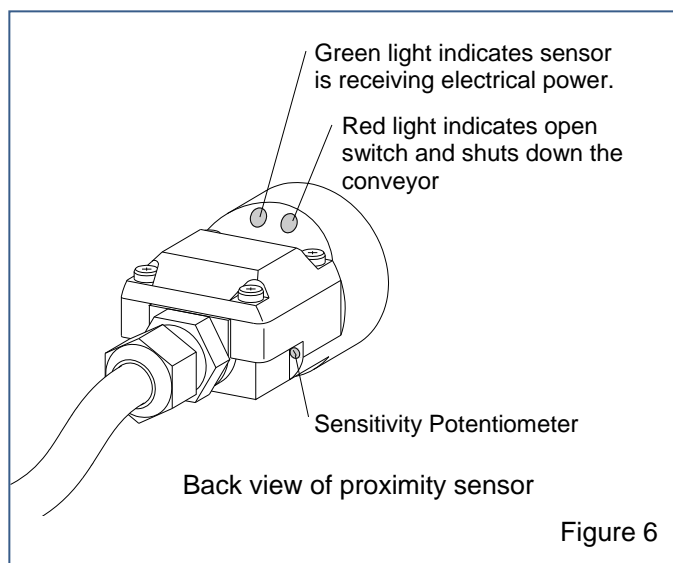

**5.3.5** Reattach the sensor mount to the support plate.

## 6.0 ABRASIVE

**6.1** Selection of blasting abrasive can adversely affect the health risk to the operator, productivity and maintenance of the blast facility. Most blast rooms with belt systems use metallic abrasive such as steel or iron grit which are favored because of their low break down rate. Slag abrasive in general is not recommended in blast rooms due to the rapid breakdown rate. **DO NOT USE** abrasives containing more than one percent crystalline (free) silica. Obtain safety data sheets (SDS) for the blasting abrasive prior to blasting, paying particular attention to the health risks and presence of any hazardous/toxic substances.

**6.2** Abrasive plays a significant part in both the productivity and maintenance of the blast facility. Metallic abrasives, such as steel or iron grit are favored because of their low break down rate. Mineral abrasive in general are not recommended for an air-wash abrasive cleaner due to the rapid breakdown rate.

## 6.3 Abrasive Size

**6.3.1** Abrasive size impacts the desired profile, cleaning rate, nozzle size and necessity of clean dry air. Generally, larger and denser abrasives provide a deeper profile, while smaller abrasives clean faster. Most abrasive blasting is done with abrasive sizes between 16 and 80 mesh. Larger sizes may be used if the nozzle orifice is large enough to allow multiple abrasive particles to pass through the nozzle without jamming. Finer abrasives are especially sensitive to moisture and require dry air to prevent bridging in the metering valve.

**6.3.2** The "working mix" of the abrasive is important to the blasting operation. When first charging the system, the abrasive mesh size should be the size which produces the desired production rate for the type of material being removed from the part, as well as the desired surface profile (etch). As the abrasive breaks down, each particle becomes a smaller mesh size. To compensate for the breakdown, an abrasive size larger than the original charge size is often added when abrasive replenishment is required. This working mix averages out to produce the required profile and production rate. Establishing the working mix is largely by trial and error as it depends upon the breakdown rate of the abrasive used, the nature of the surface being blasted, and the desired results.

## 6.4 Abrasive Capacity

**6.4.1** Calculate the storage capacity of each component except the blast machine. A Clemco 6 cubic foot blast machine holds roughly 1500 lbs. of steel or iron grit or 600 lbs. of non-metallic abrasive that has a density of 100 lbs. per cubic foot. A Clemco abrasive cleaner holds 10 cubic feet (2500 lbs. of metallic or 1000 lbs. of non-metallic abrasive). A standard 50 cubic foot hopper holds an additional 50 cubic feet of abrasive.

**6.4.2** If there is not an additional storage hopper, the recovery system should not be filled with more than a total of 10 cubic feet (2500 lbs. of metallic abrasive). Ten cubic feet of abrasive will fill a Clemco 6-cubic-foot blast machine and Clemco abrasive cleaner, to about 12 inches above the bottom of the abrasive cleaner, or half way up the access door, providing 6 cubic feet in the machine and 4 cubic feet in the abrasive cleaner.



---

## **NOTICE**

---

**During blasting, the pop-up valve (blast machine filling port) is sealed, preventing abrasive from re-entering the blast machine. As abrasive is recovered, the abrasive level in the abrasive cleaner rises. When the blast machine is empty, the abrasive cleaner will be nearly filled to its full capacity of 10 cubic feet. When the operator stops blasting, the pop-up valve automatically drops, permitting stored abrasive to refill the blast machine.**

---

**6.4.3** The only time more than 10 cu. ft. of abrasive may be loaded into a system without a storage hopper, is when a sweep-in (partial floor area recovery, not a full recovery floor) conveyor is used, and recovery does not take place until the operator stops blasting to recover abrasive. Sweep-in system may be loaded with 16 cu. ft. of abrasive. A storage hopper increases the abrasive storage capacity per the size (cubic feet) of the hopper.

### 6.5 Loading Abrasive

---

## **NOTICE**

---

**If the purchase contract includes a start-up technician, do not load abrasive until instructed to do so by the technician. Premature abrasive loading by an untrained operator can result in blockages requiring extensive cleaning.**

---



---

## **NOTICE**

---

**Observe the following to avoid overfilling, blockage, and possible damage. Blockage or overfilling will require extensive cleaning or repair.**

- **Do not load abrasive until motor rotation is checked and operational on all recovery components.**
  - **Never load abrasive unless all recovery components are operating.**
  - **Some abrasive will remain in non-recoverable areas. This filler abrasive should be compensated for only after running the system for a couple of days. Do not increase the initial charge, as it can overload the system.**
- 

**6.5.1** When initially charging the system with abrasive, use only about six cubic feet, and thoroughly check the operation of the recovery and blast system.

**6.5.2** Load abrasive by pouring it through the grating and into the hoppers, as the system is operating. Observe the movement of abrasive on the conveyor(s), flow into the elevator feed hopper, inlet chute and through the bucket elevator, and into the abrasive cleaner.

**6.5.3** Check the operation of the blast machine to make sure it is operating correctly.

**6.5.4** After confirming that the system is operating correctly, add the remaining abrasive.

---

## **NOTICE**

---

**Never add abrasive unless all recovery components are operating. Overfilling, blockage, and possible damage will occur requiring extensive cleaning out.**

---

**6.5.5** Observe belt tracking as abrasive is loaded onto the belt and readjust if necessary.

---

## **NOTICE**

---

**Never add new abrasive unless all recoverable abrasive has been retrieved into the blast machine and abrasive cleaner. Doing so will overfill the cleaner.**

---

**6.5.6** Some abrasive will remain in non-recoverable areas between grating bars, elevator boot, and corners. This filler abrasive should be compensated for only after running the system for a couple of days. Do not increase the initial charge, as it can overload the system.

### 6.6 Unloading Abrasive

**6.6.1** To empty the blast machine and hopper of abrasive, reduce pressure to 40 psi. Place an empty container, such as a drum, in the blast room. Close the choke valve and begin blasting, direct abrasive flow into the container. Empty the container when full or before it is too heavy to handle, and repeat the process until the machine is empty. If complete purging of abrasive is necessary, use a vacuum to remove abrasive from the recovery floor, hopper and blast machine head.

---

## 7.0 MAINTENANCE

### DANGER

**Lockout and tagout power before performing any maintenance on or near the conveyor. Unexpected startup can cause pinching hazards resulting in severe injury or death. All maintenance should be performed by a qualified person who is familiar with the operation of the equipment. When power is required to perform maintenance or service, make sure loose clothing and articles are removed and secured away from moving parts. Enlist the aid of other person(s) to observe and stand by to immediately shut off power if necessary.**

### 7.1 WEEKLY

**7.1.1 Check Belt Tension:** During the first month of operation, empty belt and check tension weekly. Check the tension monthly thereafter.

**7.1.2 Check Belt Tracking:** Make sure belt is tracking in the center of the idler roller and drive roller.

**7.1.3 Inspect Underside of Belt:** Jog the motor and inspect the underside of the belt for abrasive and dust. Clean as necessary.

### 7.2 MONTHLY

**7.2.1 Belt Wear:** With the belt empty, inspect the top and underside for abnormal wear. Chafing on the belt indicates that an inspection should be scheduled as soon as possible. Inspection requires lifting the conveyor from the pit. Make sure the take-up idler roller, and upper and lower support rollers rotate freely. Make sure the belt does not rub on any structural parts and the area is free of foreign materials.

**7.2.2 Rollers:** Inspect the drive and idler rollers for wear.

### 7.3 SEMI-ANNUALLY

**7.3.1 Conveyor Pit:** Vacuum and otherwise remove any abrasive, dust and debris from the conveyor pit.

**7.3.2 Belt Wear:** Thoroughly inspect the top and bottom side of the belt for wear. Closely monitor any abnormal wear.

**7.3.3 Idler Rollers:** Thoroughly inspect the take-up idler roller, and upper and lower support rollers for wear. Make sure they all rotate freely.

**7.3.4 Drive Roller:** Thoroughly inspect the drive roller for wear.

### 7.3.5 Lubricate Take-Up Bearings

### WARNING

**Lockout and tagout electrical power to prevent activation of the conveyor. Unexpected startup while working around moving parts of the conveyor can result in severe injury.**

**7.3.5.1 Lockout and tagout power** and remove the protective cap from the grease fitting on the take-up bearings and clean the fitting. Prepare the area to lubricate the bearings safely while the belt is running. Use a grease gun that removes the operator from moving parts of the belt and bearing area.

### WARNING

**If it is deemed unsafe to lubricate the bearings while the conveyor is running, lockout and tagout power and lubricate the still bearings.**

**7.3.5.2** Slowly pump in lithium-based grease that conforms to NLGI Grade 2 consistency, until a slight bead forms around the seals.

**7.3.5.3** Shut off power before removing the grease gun from the fitting.

**7.3.5.4** Wipe the fitting to remove grease before replacing the protective cap on the fitting.

### 7.4 ANNUALLY

#### 7.4.1 Conveyor Service

Schedule a convenient time annually, to disconnect electrical power and lift the conveyor assembly from the pit.

**7.4.1.1** Thoroughly vacuum the top and underside of the belt and inspect the belt for wear.

**7.4.1.2** Have a qualified electrician apply temporary power and while standing away from the conveyor observe the operation of the belt and rollers. Make sure the take-up idler roller, and upper and lower support rollers rotate freely.

**7.4.1.3** Disconnect the temporary power and make repairs as needed. Return the conveyor to service.

---

## 8.0 TROUBLESHOOTING

### **DANGER**

Some troubleshooting requires the belt conveyor and bucket elevator to be running. Extreme care must be taken to keep hands, tools, clothing, etc., away from the belts while the conveyor is running. Any limbs, loose clothing, tools or any other articles, caught between the belt, pulley, or are caught on a roller or will cause severe injury. When conveyor operation is not required, make sure an approved electrical lockout and tagout procedure is done to prevent activation of the conveyor during service. Unanticipated starting of the conveyor can cause severe injury.

---

## 9.0 REPLACEMENT PARTS

Refer to belt conveyor assembly drawings for replacement parts

### 8.1 Belt drifts to one side

**8.1.1** Adjust belt tension and tracking per Section 5.1. Adjust the tension using the take-up screws at the idler end of the conveyor. Do not use the adjustment screws at the drive (motor) end. These screws are only used to center the belt on the drum motor.

### 8.2 Elevator feed hopper overfills

**8.2.1** Conveyor drum motor running too fast; reduce motor speed. Do not reduce below 30 Hz. Refer to Section 5.2.

**8.2.2** Elevator not picking up enough abrasive; refer to bucket elevator manual, Stock No. 21822, to adjust the inlet-chute slide gate.

### 8.3 Abrasive spills-over the discharge chute; belt does not shutdown

**8.3.1** Proximity switch not set at maximum sensitivity. Refer to Section 5.3.

### 8.4 Elevator inlet chute under-fills and hoppers remain full

**8.4.1** Drum motor running too slow; increase motor speed. Do not increase above 60 Hz. Refer to Section 5.2.

**8.4.2** Blockage in conveyor hopper(s); inspect hopper openings for blockage.

---