

WETBLAST INJECTOR™ SYSTEM

O. M. 05539

DATE OF ISSUE: 04/83
REVISION: F, 09/21

WARNING

Do not use this equipment before **READING this **MANUAL** and **UNDERSTANDING** its contents.**

These **WARNINGS are included for the health and safety of the operator and those in the immediate vicinity. Failure to read and understand these warnings can result in injury or death.**

Electronic files include a preface containing the same important information as in the orange cover.

© 2021 CLEMCO INDUSTRIES CORP.
One Cable Car Dr.
Washington, MO 63090
Phone (636) 239-4300
Fax (800) 726-7559
Email: info@clemcoindustries.com
www.clemcoindustries.com



1.0 INTRODUCTION

1.1 Scope of manual

1.1.1 These instructions cover the setup, operation, maintenance, troubleshooting, and replacement parts for Clemco's Wetblast Injector™ System.

1.1.2 Read this manual, plus the manual for the operation and maintenance of the pump. This manual does not contain important safety information regarding the use of abrasive blasting equipment and the application with which the injector system is used. All operators and personnel involved with the abrasive blast process must read and understand the contents of these instructions, including the orange cover and operations manuals for the blast machine and the accessories used with the injector system. Manuals containing operation and important information for Clemco abrasive blasting equipment are available on Clemco's website: www.clemcoindustries.com,

1.1.3 All personnel involved with the abrasive blasting process must be made aware of the hazards associated with abrasive blasting. The Clemco booklet "Abrasive Blasting Safety Practices" is included with every blast machine, and it contains important safety information about abrasive blasting that may not be included in equipment operations manuals. To request additional copies, visit www.clemcoindustries.com or email info@clemcoindustries.com.

1.2 Safety Alerts

1.2.1 Clemco uses safety alert signal words, based on ANSI Z535.4-2011, to alert the user of a potentially hazardous situation that may be encountered while operating this equipment. ANSI's definitions of the signal words are as follows:



This is the safety alert symbol. It is used to alert you to potential physical injury hazards. Obey all safety messages that follow this symbol to avoid possible injury or death.

NOTICE

Notice indicates information that is considered important, but not hazard-related, if not avoided, could result in property damage.

CAUTION

Caution indicates a hazardous situation that, if not avoided, could result in minor or moderate injury.

WARNING

Warning indicates a hazardous situation that, if not avoided, could result in death or serious injury.

DANGER

Danger indicates a hazardous situation that, if not avoided, will result in death or serious injury.

1.3 Table of Contents

SUBJECT	LOCATION
INTRODUCTION	1.0
Scope of Manual	1.1
Safety Alerts	1.2
Table of Contents	1.3
Components	1.4
Instruction Maintenance Manuals	1.5
Description and Operating Principles	1.6
Compressed-Air Requirements	1.7
Water Requirements	1.8
Rust Inhibitors and Additives	1.9
SETUP	2.0
Blast Machine and Accessories	2.1
Connect Air Hose	2.2
Connect Water-Supply Hose	2.3
Water from a faucet	2.3.1
Water from a storage tank	2.3.2
Attach Injector Adaptor to Blast Hose	2.4
Connect Hydraulic Hose	2.5
Using Nozzle Injector with Additional Blast Machine	2.6
Identify Water Pumps that Require Lubrication	2.7
OPERATION	3.0
Pre-Blast Inspection and Settings	3.1
Blasting Attire	3.2
Start Blasting	3.3
Adjust Water Flow	3.4
Abrasive, Air, and Water Flow Options	3.5
Dry blasting	3.5.1
Wet Abrasive Blasting	3.5.2
Wash-Down	3.5.3
Air Drying	3.5.4
Stop Blasting	3.6
Shutdown	3.7

ADJUSTMENTS 4.0
 Water Pump Lubricator, required on prior models 4.1
 Air-Drive Supply Pressure (controls water pressure) . 4.2
 Water Flow 4.3

PREVENTIVE MAINTENANCE 5.0
 Water Pump Lubricator, Refer to Section 2.7 5.1
 Daily Inspection 5.2
 Weekly Inspection 5.3
 Periodic Inspection 5.4
 Operating in Freezing or Near Freezing Conditions 5.5

SERVICE MAINTENANCE 6.0
 Replacing Injector Sleeve 6.1
 Water Pump 6.2

TROUBLESHOOTING 7.0
 No water from the injector 7.1
 Pump does not prime 7.2

ACCESSORIES and REPLACEMENT PARTS 8.0
 Wetblast Injector Systems 8.1
 Pump Module 8.2
 Injector-Adaptor Assemblies and Parts 8.3

1.4 Components

1.4.1 Components of the Wetblast Injector System with typical water set-ups are shown in Figure 1, and include:

Pump Module, consisting of:

- Enclosure with external compressed air and water connections.
- Air filter/pressure regulator combination, adjust air pressure to the water pump (maximum of 100 psi).
- 10:1 Air-driven water pump.

50 ft hydraulic (high-pressure water) hose assembly.

Wetblast nozzle injector-adaptor assembly, one of the following options to match the configuration of the nozzle holder and nozzle.

- 50 mm contractor nozzle threads with 1-1/4" entry.
- 50 mm contractor nozzle threads with 1" entry.
- 1-1/4 nozzle threads with 1" entry.

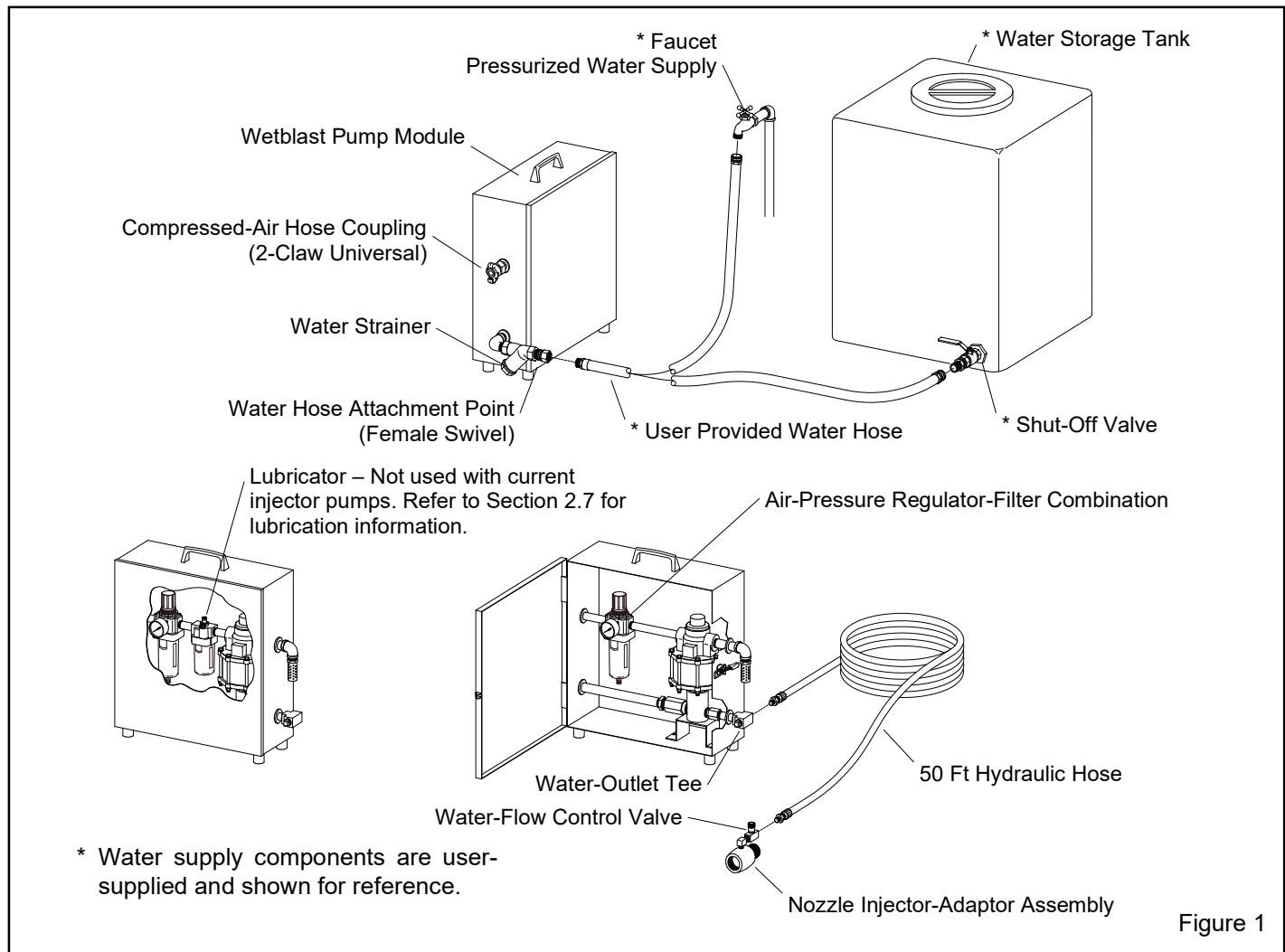

Figure 1

1.4.2 External inlet connections are located on the left side on the module. They include a 2-claw universal compressed-air supply connection and water supply strainer with female-swivel water connection.

1.4.3 External outlet connections are located on the right side of the module and include the exhaust muffler and water-outlet tee. The water-outlet tee is the attachment for the hydraulic (water) hose. The other end of the hose connects to the injector-adaptor assembly located at the nozzle.

1.5 Instruction Maintenance Manuals

1.5.1 After reviewing all the manuals, and start-up and adjustments are completed, store manuals in a convenient location for future reference.

1.6 Description and Operating Principles

1.6.1 The Wetblast Injector is a stand-alone system that provides water injection capability to any dry

abrasive-blast machine. The unique water-injection design, combined with precise abrasive and water metering, reduces or eliminates dust normally found with dry blasting operations. The illustration in Figure 2 shows a typical set up with a blast machine.

1.6.2 When a compressed-air line and water source are connected, incoming air is adjusted at the regulator /filter to a suitable pressure and filtered through the air filter segment.

1.6.3 Compressed air operates the pump, which pressurizes water at a 10:1 ratio, meaning water outlet pressure is ten times that of incoming air pressure. Maximum operating air pressure to the pump is 100 psi. Refer to Section 4.2 to adjust pump pressure.

1.6.4 When the blast machine and wetblast injector are set up, the system is ready for operation. The operator will dry blast long enough to get the correct air abrasive mixture. When ready, the operator opens the

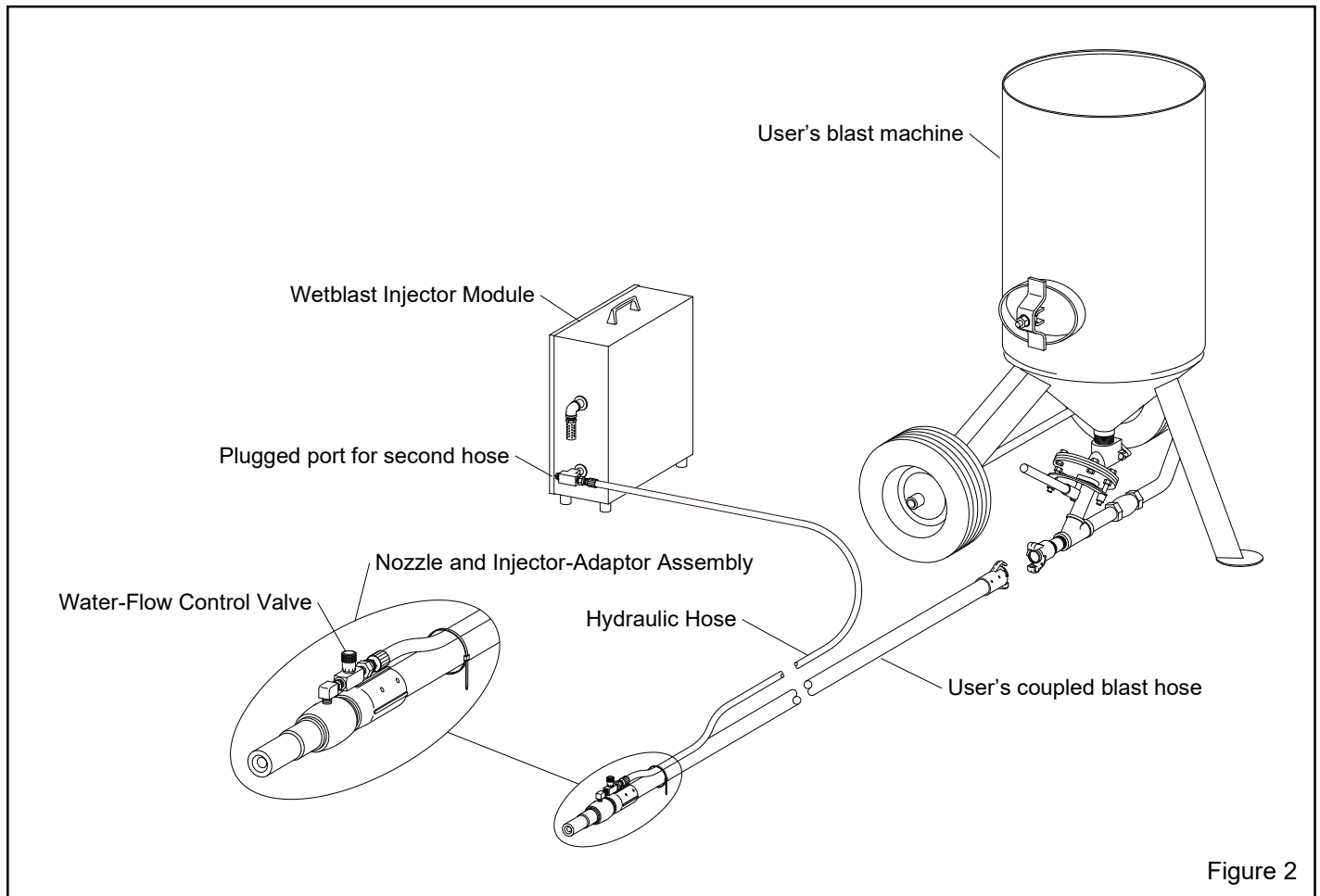

water-flow control valve on the injector adaptor, which injects water into the air and abrasive blast stream through an array of jets within the adaptor. Water entering the blast stream combines with air and abrasive, and is accelerated as they pass through the nozzle. Each abrasive particle is thoroughly engulfed in moisture before it impacts the blast surface and shatters. The process drastically reduces or eliminates dust in the atmosphere.

1.6.5 When set up with any standard blast machine, the operator has the ability to switch between dry blasting and wet blasting from the nozzle.

When set up with a blast machine that has a pneumatically-operated abrasive metering valve, the operator can control abrasive, air, and water, or any combination of the three, isolating the four following functions.

- Dry blasting, with air and abrasive only
- Wet blasting, with air, abrasive, and water.
- Wash-down, with air and water only.
- Dry-off (air drying), with air alone

Wash-down and drying can be done with a blast machine having a manually-operated abrasive control valve by manually closing the valve at the machine.

1.6.6 The injector system can be used by two operators simultaneously by adding a second hydraulic hose, injector adaptor, and another blast machine. The plugged port on the unused leg of the water-outlet tee is for a second nozzle injector. Refer to Sections 2.4 and 2.5.

1.7 Compressed-Air Requirements

1.7.1 The pump consumes a maximum of 30 cfm. The cfm consumption is based on operating at a maximum of 100 psi, which is the maximum operating pressure for the pump. Pump pressure is typically set between 35 to 40 psi. Refer to Section 4.2 to adjust pump pressure.

1.8 Water Requirements

1.8.1 The water supply to the injector can be from a prefilled water storage tank or pressurized water from a faucet. Refer to Section 2.3 for water connections.

1.9 Rust Inhibitors and Additives

1.9.1 Additives may be used in a storage tank when premixed with water at the recommended dilution. **NOTE:** Always check with the coating manufacturer prior to use to ensure the additive is compatible with the coating to be applied.

2.0 SET UP

2.1 Blast Machine and Accessories

2.1.1 Set up the blast machine, operator safety equipment and all accessory equipment following manufacturer's instructions.

NOTE: Unless noted otherwise, the sequence of assembly in Section 2 may be done in any order that is best suited for the application. To protect the brittle nozzle liner from damage, it is suggested that the user-supplied nozzle be placed in the injector after all other connections are made.

2.2 Connect Air Hose – Figure 3

⚠ WARNING

If twist-on (claw-type) air hose couplings are used, they must be secured with safety lock pins or wires to prevent accidental disconnection while under pressure. Use safety cables to prevent hose whipping should a separation occur. Hose disconnection while under pressure could cause serious injury.

2.2.1 Attach a 1/2" ID or larger air hose to the 2-claw coupling, as shown in Figure 3. **NOTE:** If the user-supplied air hose has a different type of coupling, replace the coupling on the injector with one that is compatible with the hose. Make sure there are no reducers or restrictions that reduce the volume of air (30 cfm at 100 psi) required for the pump.

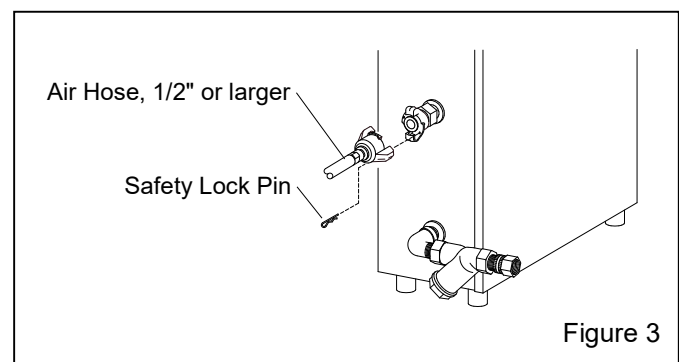

2.3 Connect Water-Supply Hose

2.3.1 Water from a faucet

2.3.1.1 Attach a water hose to the 3/4" garden hose swivel connector on the strainer. The water source may be from a faucet, as shown in Figure 4, or from a storage tank, as noted in Section 2.3.2 and shown in Figure 5.

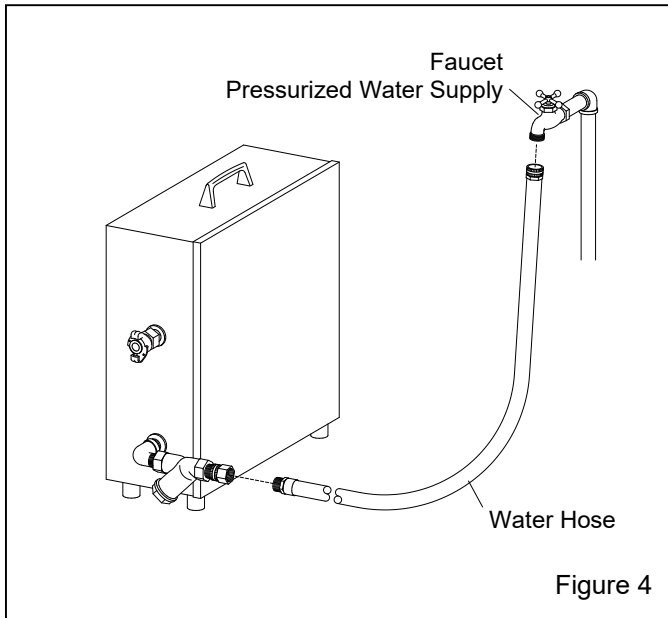

2.3.1.2 Do not connect the injector adaptor directly to a faucet. Water to the injector must pass through the pump to overcome pressure in the blast hose.

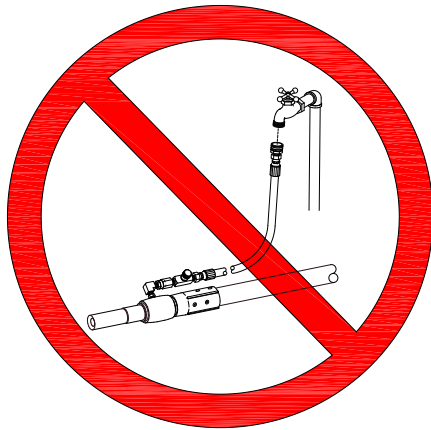

CAUTION

Do not connect the injector adaptor to any water supply except through the pump module. Using the injector without the pump, such as connecting it directly to a faucet could cause pressure in the blast hose to backup into the water system and cause extensive damage, and in certain conditions can result in injury.

2.3.1.3 The pump is easily primed when the water supply is from a pressurized faucet. Water pressure pushes water through the pump, eliminating air pockets.

2.3.2 Water from a storage tank – Figure 5

2.3.2.1 When water is supplied from a storage tank, make sure the tank is vented and that the outlet is elevated higher than the injector's water connection inlet. If there is difficulty in priming the pump, install a small air valve (facing up) at the inlet to burp air trapped in the supply line.

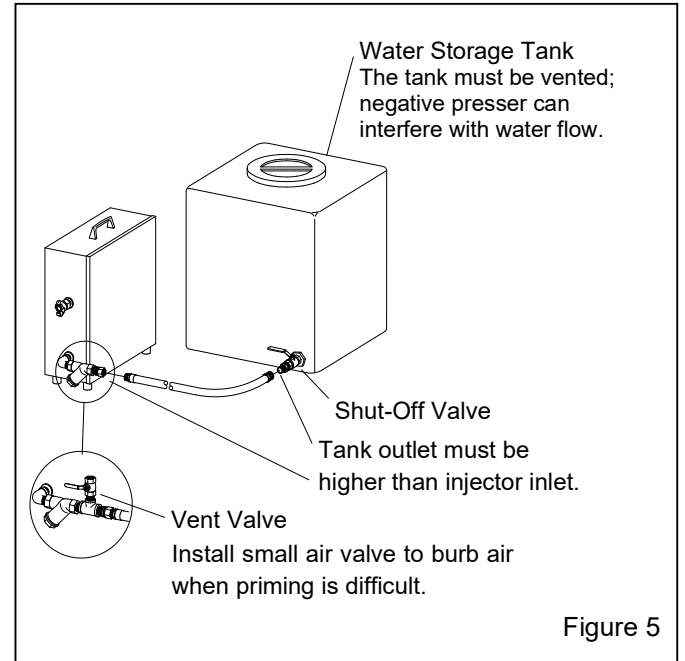

NOTICE

When using water from a tank, make sure the connection at the injector is lower than the outlet of the tank. The pump is self-priming, but it may not prime if the injector inlet is higher than the storage tank outlet. Refer to Section 3.1.7 to prime the pump.

2.4 Attach Injector Adaptor to User-Supplied Blast Hose – Figure 6

2.4.1 Place the nozzle washer provided with the injector into the nozzle holder. Thread the injector into the nozzle holder and firmly compress the washer between the injector and holder, as shown in Figure 6. Rotate the water-flow control valve, positioning the knob so the operator with a gloved hand can turn the knob to regulate water flow.

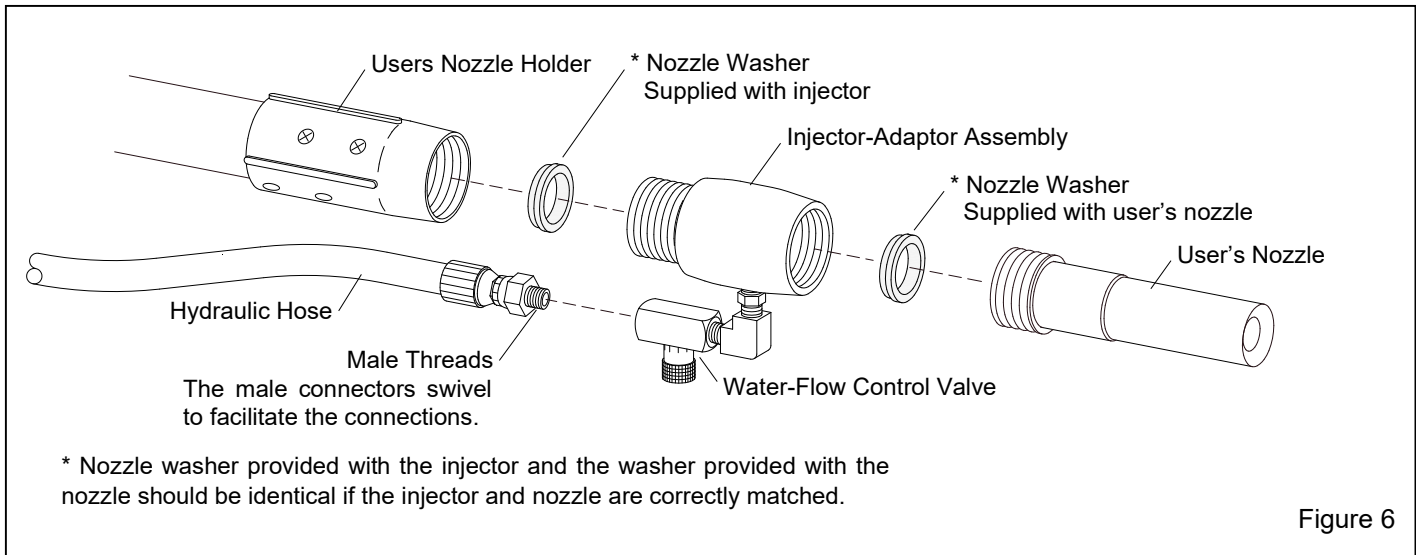

2.4.2 After all blast hose and water hose connections are made and just before blasting, place the nozzle washer into the injector-adaptor assembly and screw the nozzle firmly into adaptor.

NOTE: When a hydraulic hose extension is needed, connect hoses together using hose coupling 02162, shown in Section 8.2, Figure 13.

NOTICE

The nozzle washers must be firmly compressed to create an airtight seal between the blast hose, injector, and nozzle. Air leaks will erode the threads or otherwise damage these items.

2.5 Connect Hydraulic Hose – Figures 6 and 7

2.5.1 Apply thread sealant to the male threads on one end of the 50 ft hydraulic hose and connect it to the injector-adaptor, as shown in Figure 6. The male connectors on both ends of the hydraulic hose swivel to facilitate the removal and reattachment of the hose.

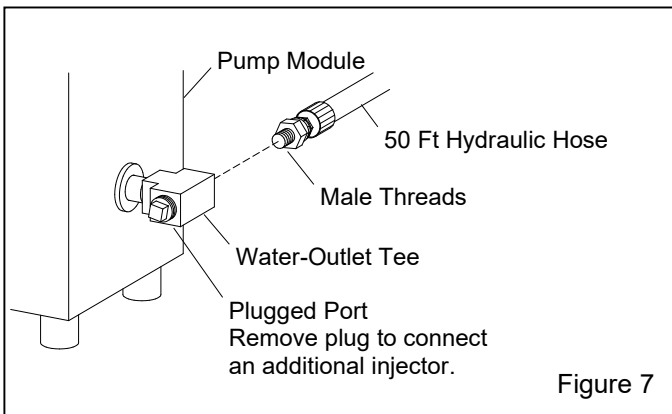

2.5.2 Apply thread sealant to the male threads on the other end of the 50 ft hydraulic hose and connect it to the tee located on the side of the pump module, as shown in Figure 7.

2.6 Using Nozzle Injector with Additional Blast Machine

2.6.1 When a separate blast machine is used with the injector, remove the plug on the module's outlet tee, as shown in Figure 7, and connect an additional hydraulic hose and injector by following the instructions in Sections 2.4 and 2.5.

2.7 Identify Water Pumps that Require Lubrication

2.7.1 Water pumps used with current injector system are pre-lubricated and do not require additional lubrication. Systems that require lubrication are identified by an inline lubricator located within the pump-module enclosure, as shown in Figure 8. Open the enclosure door to access the lubricator.

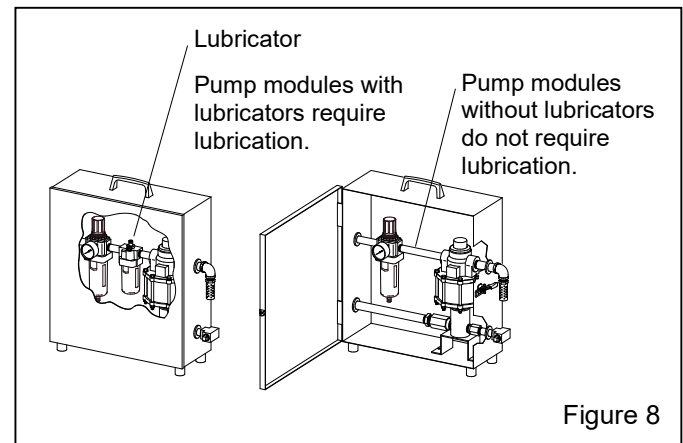

2.7.2 Refer to the label on the pump for the pump model. The pumps are identical except the 10-5 series is pre-lubricated at factory, and therefore does not require a lubricator in the air-drive supply line. The addition of the letter "L", the 10-5L series has a suffix to denote the pump requires a lubricator in the air-drive supply line.

Refer to the label on the pump for the pump model

SC Hydraulic Pump Model	Lubrication Requirement
10-5000W005 (10-5 series)	Lubricant not required
10-5000W005L (10-5L series)	Lubricant is required

NOTE: Lubrication instructions are provided for those that download or otherwise obtain this manual for use with injector systems having 10-5L Series Pumps.

3.0 OPERATION

3.1 Pre-Blast Inspection and Settings

3.1.1 Make sure the blast machine and operator safety equipment are set up per instructions in the applicable manual.

3.1.2 Make sure air hose connections are secure and wired with safety lock pins.

3.1.3 Make sure water supply hose is connected to an adequate water source.

3.1.4 Make sure the water pump lubricator (refer to Section 2.7 to identify pumps that require lubrication) is filled with approved lubricant.

3.1.5 Make sure the water-flow control valve is closed (knob turned fully-clockwise), as shown in Figure 11.

3.1.6 Turn the pressure regulator control knob counterclockwise to "0" psi. Refer to Section 4.2 to regulate pressure.

3.1.7 Prime pump

3.1.7.1 Pressurize the air-supply line to the pump module.

3.1.7.2 Open the water supply valve.

3.1.7.3 Slowly increase the pump air pressure to 10 - 15 psi, per Section 4.2. The pump should begin to stroke rapidly as soon as air is applied.

3.1.7.4 Open the water-flow control valve, the pump should prime itself and water flow should start within a few second. Pump stroke should slow as water pressure builds between the pump and injector.

NOTICE

Make sure the water supply reaches pump within a few seconds of starting. Running the pump dry will damage the hydraulic piston and cylinder assembly.

3.1.7.5 Slowly increase air pressure to 30 - 40 psi and let pump run until all air has been purged from the system.

3.1.7.6 Close the water-flow control valve.

3.1.7.7 If pump does not self-prime from the water tank, and if pressurized water (from a faucet) supply is available, repeat the process using pressurized water. If pressurized water is not available, install a small vent valve, as noted in Section 2.3.2 - Figure 5.

3.2 Blasting Attire

WARNING

Before blasting, test the coating and substrate for toxic materials (such as lead or other heavy metals, or asbestos). These hazards require special measures to protect the operators and the environment.

No dust is safe to breathe. Dry abrasive blasting produces harmful dust. Although blasting with water injection reduces dust at the blast surface, supplied air respirators are required for the safety of the operator. Evaporation can cause dust to become airborne. Failure to wear approved respirators can result in serious lung disease or death. Blast operators must wear properly-fitted and maintained NIOSH-approved, type-CE supplied-air respirators approved for abrasive blasting.

During abrasive blasting, abrasive particles and dust in the area around the blast machine and blast nozzle become airborne. Everyone working in the vicinity of abrasive blasting must wear properly-maintained, NIOSH-approved, respiratory protection and eye protection appropriate for the job site hazards.

Loud noise generated by the use of compressed air can cause hearing damage. Everyone in the blasting area must wear approved hearing protection.

3.2.1 Don all protective, blasting attire per applicable operations manuals.

3.2.2 Do not allow anyone near the blast machine except machine tenders, who are appropriately attired in approved protective equipment.

3.3 Start Blasting

3.3.1 Pressurize blast machine and begin dry blasting.

3.3.2 Adjust abrasive flow.

3.4 Adjust Water Flow

3.4.1 Slowly open the water-flow control valve to begin water flow, adjust flow, per Section 4.3

3.5 Abrasive, Air, and Water Flow Options

3.5.1 Dry Blasting: When the water-flow control valve is closed, dry abrasive blasting is done by following the instructions provided with the blast machine.

NOTICE

To avoid unnecessary wear to the injector, remove it when wet blasting is not required.

3.5.2 Wet Abrasive Blasting: Open or close the water-flow control valve anytime during dry blasting to start and stop wet blasting.

3.5.3 Wash-Down: While wet blasting, close the abrasive metering valve; air and water continue to exit the nozzle. The pot tender can manually close the metering valve or, when a pneumatically-operated metering valve such as a Clemco Auto-Quantum and abrasive cut-off switch (ACS) is used, abrasive shut-off can be done from the nozzle while.

3.5.4 Air Drying: When water and abrasive flow are shut off (both operations can be performed at the nozzle with a pneumatically-operated metering valve such as a Clemco Auto-Quantum and ACS option), air alone exits the nozzle to blow dry the surface.

3.6 Stop Blasting

3.6.1 Turn the water-flow control valve OFF before stopping blasting, per instructions provided with the blast machine and accessories.

3.7 Shutdown

3.7.1 Empty the blast machine of abrasive and shutdown the blast machine following the manufacturer's instructions.

3.7.2 Close the compressed-air supply valve at the compressor.

3.7.3 Close the water supply valve.

3.7.4 Point the nozzle downward, to prevent water from entering the blast hose, and open the water-flow control valve to drain water from the pump and hydraulic hose and to drain air from the air-supply line.

3.7.5 Disconnect the water supply hose.

NOTICE

If there is any chance that the injector components will be subject to freezing temperatures, drain all water from the pump and open the pressure-water supply valve. Failure to drain water from the system could permanently damage the pump and water connections.

3.7.6 Elevate the module or lay the blast hose and hydraulic hose on the ground to continue to drain water from the pump module and hose.

3.7.7 Check the gauge on the pressure regulator/filter, to make sure air is bled from the supply line, and then disconnect the air-supply hose.

3.7.8 When blasting is finished, disconnect all hoses and store the pump module inside protected from freezing conditions.

4.0 ADJUSTMENTS

4.1 Water Pump Lubricator – Figure 9

NOTE: Refer to Section 2.7 to identify pumps that require lubrication. Lubrication instructions are provided for those that download or otherwise obtain this manual for use with injector systems having 10-5L Series Pumps.

NOTICE

Lack of lubrication can cause premature failure of the pump. Pump damaged caused by lack of lubrication is not covered under warranty.

4.1.1 The lubricator for pumps that require lubrication is located within the pump module. Open the door to access the lubricator.

WARNING

The air supply to the pump module must be turned off and the line bled before removing the lubricator filler cap or bowl. Failure to eliminate internal air pressure could cause severe injury from the sudden release of compressed air.

4.1.2 Make sure the pump-module air-supply valve is closed and the line is bled.

4.1.3 Remove the filler cap and fill the lubricator with a good grade of petroleum-based lubricating oil such as Castrol Brayco Micronic 783, AeroShell Fluid 71, or equivalent. A good quality oil specifically manufactured for air tools may be used if the recommended lubricants are not available.

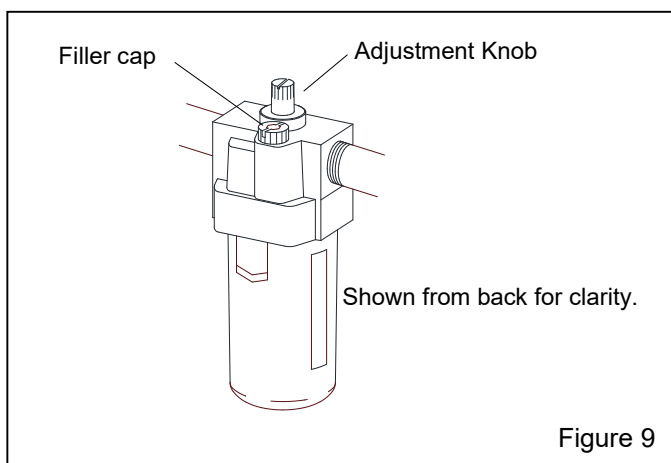

Figure 9

4.1.4 Turn the adjustment knob to provide one drop of oil for every twenty strokes of the pump. If excessive amounts of oil appear to be flowing through the pump during operation, as noted at the modules exhaust muffler, reduce the rate of lubrication.

4.2 Air-Drive Supply Pressure (Controls Water Pressure) – Figure 10

4.2.1 Water pressure is controlled with the air-pressure regulator/filter combination located within the pump module. The pump air-to-water ratio is 10 to 1, meaning water pressure is ten times air inlet pressure. For example, if the air regulator is set at 30 psi, water outlet pressure will be 300 psi. Operating air pressure is usually set between 30 and 40 psi. Maximum operating pressure for the pump is 100 psi.

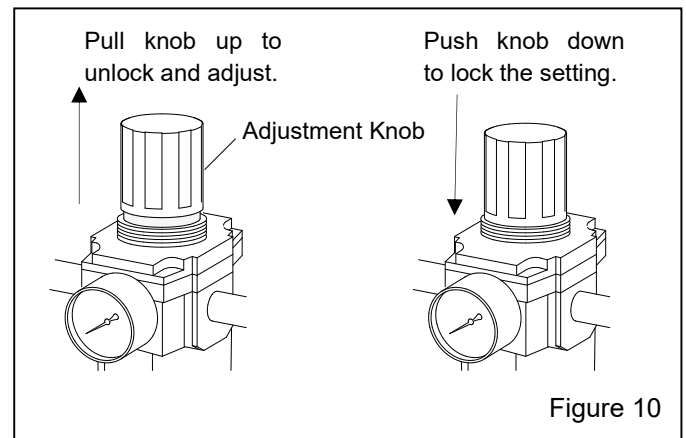
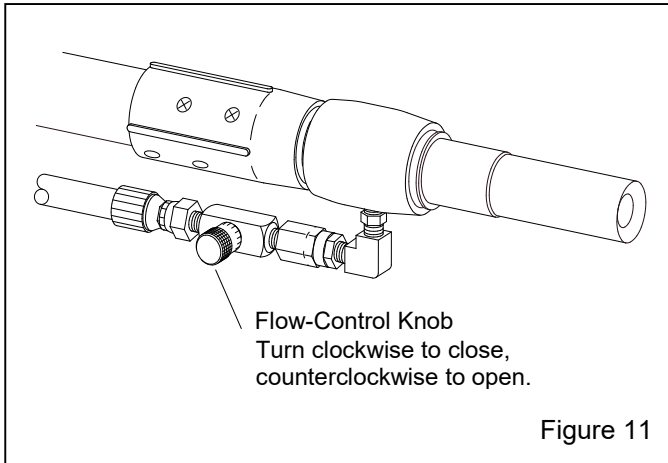

Figure 10

4.2.2 To adjust, grip the upper part of the regulator control knob and pull the knob up to unlock it, turn it clockwise to increase pressure or counterclockwise to decrease pressure. Once operating pressure is set, push in on the knob to lock it and maintain the setting.

4.3 Water Flow

4.3.1 Adjust water flow by turning the knob on the water-flow control valve. The valve is closed when the knob is turned fully-clockwise, as shown in Figure 11.



4.3.2 Begin with the flow valve fully-closed. Start blasting and slowly open the valve until the correct water to air and abrasive mixture is attained. Usually, water flow will be set with the valve about 1/2 to 3/4 turns open.

5.0 PREVENTIVE MAINTENANCE

5.1 Water Pump Lubricator

Refer to Section 2.7 for lubrication information.

5.2 Daily Inspection

5.2.1 With the air off, before blasting, do the following:

- Make sure air-drive supply pressure is set to the correct operating pressure.
- Check to make sure that air couplings are secure and lock pins and safety cables are in place.
- Make daily inspection of the blast machine and accessories, as noted in the manufacturer's operations manuals.

5.3 Weekly Inspection

5.3.1 With the air off, before blasting, do the following:

- Remove the nozzle and injector-adaptor, and inspect injector sleeve, nozzle, and washers for wear.
- Inspect the regulator/filter bowl and element; clean as necessary.
- Make weekly inspection of the blast machine and accessories, as noted in the manufacturer's operations manuals.

⚠ WARNING

The threads on the nozzle and nozzle holder must be inspected each time the nozzle is secured to the holder. A loose-fitting nozzle may eject under pressure and could cause severe injury. Check the threads for wear, and make sure the nozzle holder securely holds the nozzle. The nozzle washer must also be inspected for wear. When nozzle washers are worn, abrasive could erode nozzle threads.

5.4 Periodic Inspection

5.4.1 Remove the water-inlet strainer cap and remove the screen for inspection, clean as needed.

5.5 Operating in Freezing or Near Freezing Conditions

5.5.1 Water freezes and expands at 32° F. When shutting down, be sure to drain all water from the pump module by removing the plug on the inlet strainer.

NOTICE

If there is any chance that the injector components will be exposed to freezing temperatures, drain all water from the pump and open the pressure-water supply valve. Failure to drain water from the system could permanently damage the pump and water connections.

5.5.2 Avoid storing the module where it will subject to freezing or near freezing temperatures.

6.0 SERVICE MAINTENANCE

6.1 Replacing Injector Sleeve – Figure 12

6.1.1 Remove the hydraulic hose from the injector; the male ends of the hydraulic hose swivel to facilitate the removal and reattachment of the hose.

6.1.2 Remove the injector-adaptor assembly from the blast hose and remove the nozzle from the injector.

6.1.3 Remove the sleeve from the blast hose end of the injector-adaptor body. Abrasive and mineral deposits may make it difficult to remove; drive the sleeve out with a dowel or press it out as needed.

6.1.4 Place a new O-ring into the O-ring groove.

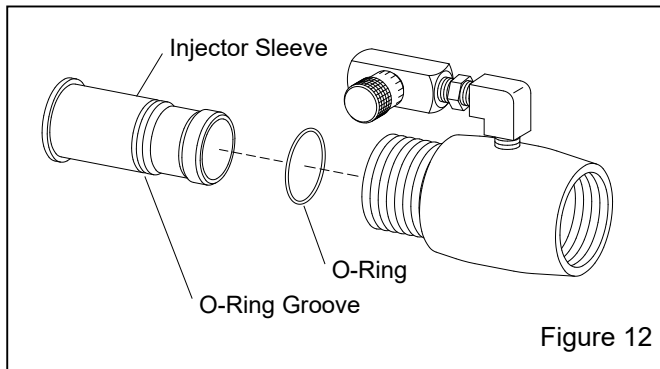

6.1.5 Lubricate the O-ring with silicone grease or similar lubricant and fully insert the sleeve into the body.

6.1.6 Make sure the nozzle washers are in good condition before connecting the injector to the blast hose and installing the nozzle.

6.1.7 Reattach the hydraulic hose.

6.2 Water Pump

Refer to the water pump manual to service the pump.

7.0 TROUBLESHOOTING

7.1 No water from the injector

7.1.1 Observe pump stroke. If pump rapidly strokes, pump is not properly primed. Refer to Section 3.1.7 to prime pump. Also, refer to Section 7.2.

7.1.2 Water-flow control valve closed or blocked. Open flow control or inspect the valve for blockage.

7.1.3 Air-supply (isolation) valve to pump module closed. Make sure the air-supply line is pressurized.

7.1.4 Water supply valve to pump module closed. Make sure water supply valve is open.

7.1.5 Pump-module pressure-regulator set too low or turned off. Check pressure and set between 30 and 40 psi.

7.1.6 Inlet strainer screen blocked. Inspect screen; clean or replace as needed.

7.1.7 Pump requires service. Refer to the pump's operations manual.

7.2 Pump does not prime, pump rapidly strokes, but does not pump water

7.2.1 Make sure all air is bled from water supply, refer to Sections 3.1.7 and 2.3.2.

7.2.2 If pump does not self-prime from the water tank, and if pressurized water (from a faucet) supply is available, repeat the priming process using pressurized water.

7.2.3 Inspect the needle valve and check valve for blockage.

7.2.4 Inlet strainer screen blocked. Inspect screen; clean or replace as needed.

8.0 ACCESSORIES and REPLACEMENT PARTS

8.1 Wetblast Injector Systems

Description	Stock No.
Wetblast injector system for one operator Includes pump module, 50 ft hydraulic hose, and one the following injector-adaptor assembly, as shown in Section 8.3, Figure 14	
05540 w/1-1/4 threads and 1" ID sleeve	05500
05541 w/cont'r threads and 1" ID sleeve	07750
05598 w/cont'r threads and 1-1/4" ID sleeve ...	07752

Wetblast injector system for two operators Includes pump module, two 50 ft hydraulic hoses, and two of the following injector-adaptor assemblies, as shown in Section 8.3, Figure 14	
05540 w/1-1/4 threads and 1" ID sleeve	05501
05541 w/cont'r threads and 1" ID sleeve	07751
05598 w/cont'r threads and 1-1/4" ID sleeve ...	07753

8.2 Pump Module – Figure 13

Item	Description	Stock No.
1.	Pressure regulator/filter, 1/2 NPT.....	05530
2.	Pump, water injector	05532
3.	Muffler, 3/4-NPT air	05529
4.	Grommet, 7/8" ID rubber	00183
5.	Grommet, 1" ID rubber	00184
6.	Foot, cabinet enclosure, each	05525
7.	Adaptor, 3/4-FPT x fem water swivel	05524
8.	Strainer, 3/4-NPT water, 100 mesh	15011
9.	Hose, Hydraulic, 50 ft x 3/8" ID	05527
10.	Coupling, 1/2-FPT 2-claw	00594
11.	Gauge, 1/8-NPT CBM, replacement	01908
12.	Handle, cabinet enclosure	05526
13.	Elbow, galvanized 3/4-NPT 90° St.	10935
14.	Elbow, 3/4-NPT 90°	01729
15.	Nipple, 3/4-NPT galvanized	01746
16.	Tee, 1/2-NPT, brass	03990
17.	Bushing 1/2-NPT x 1/4 NPT, brass	02706
18.	Plug, 1/4-NPT	01950
19.	* Lock pin, coupling (package of 25)	11203
20.	* Coupling, 1/4-FNP hydraulic hose	02162
21.	* Service kit, injector pump, includes air motor kit and hydraulic kit	05484
22.	** Lubricator, 1/2-NPT	05531

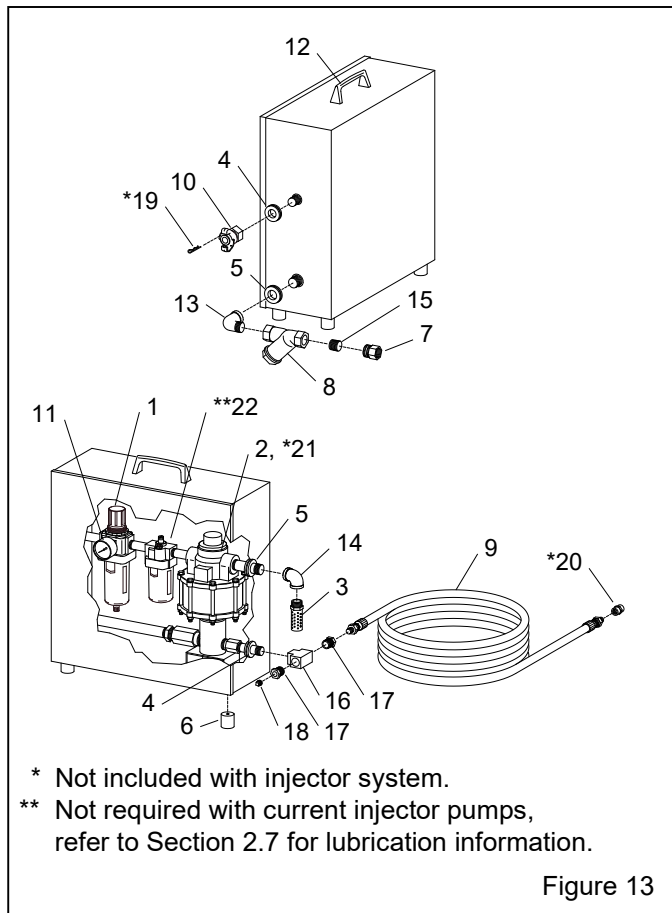

8.3 Injector-Adaptor Assemblies – Figure 14

Item	Description	Stock No.
1.	Injector-adaptor assembly 1-1/4" nozzle thread, 1" ID sleeve	05540
2.	Injector-adaptor assembly cont'r nozzle thread, 1" ID sleeve	05541
3.	Injector-adaptor assembly cont'r nozzle thread, 1-1/4" ID sleeve	05598
4.	Body, 1-1/4" threaded adaptor.....	05506
5.	Body, contractor threaded adaptor	05507
6.	Injector sleeve assembly, 1" ID for 5540 includes items 9, 13, and 14	05536
7.	Injector sleeve assembly, 1" ID for 5541 includes items 10, 12, and 15.....	05534
8.	Injector sleeve assembly, 1-1/4" ID for 5598 includes items 11, 12, and 16	05535
9.	Sleeve, 1" ID injector, for 1-1/4" body	05508
10.	Sleeve, 1" ID injector for cont'r body	05509
11.	Sleeve, 1-1/4" ID injector for cont'r body ..	05510
12.	O-ring, 1-3/8 ID	05516
13.	O-ring, 1-1/4" ID	05523
14.	Washer, NW-4 nozzle, pack of 10	00869
15.	Washer, NW-25 nozzle, pack of 10	91024
16.	Washer, NW-32 nozzle, pack of 10	91026
17.	Elbow, 1/4-NPT 90° st.	02027
18.	Nipple, 1/4-NPT hex	02808
19.	Valve, 1/4-NPT water flow control	05528

